

RADU ROBERT AXAC

MAPA – DESEN PROIECTIV

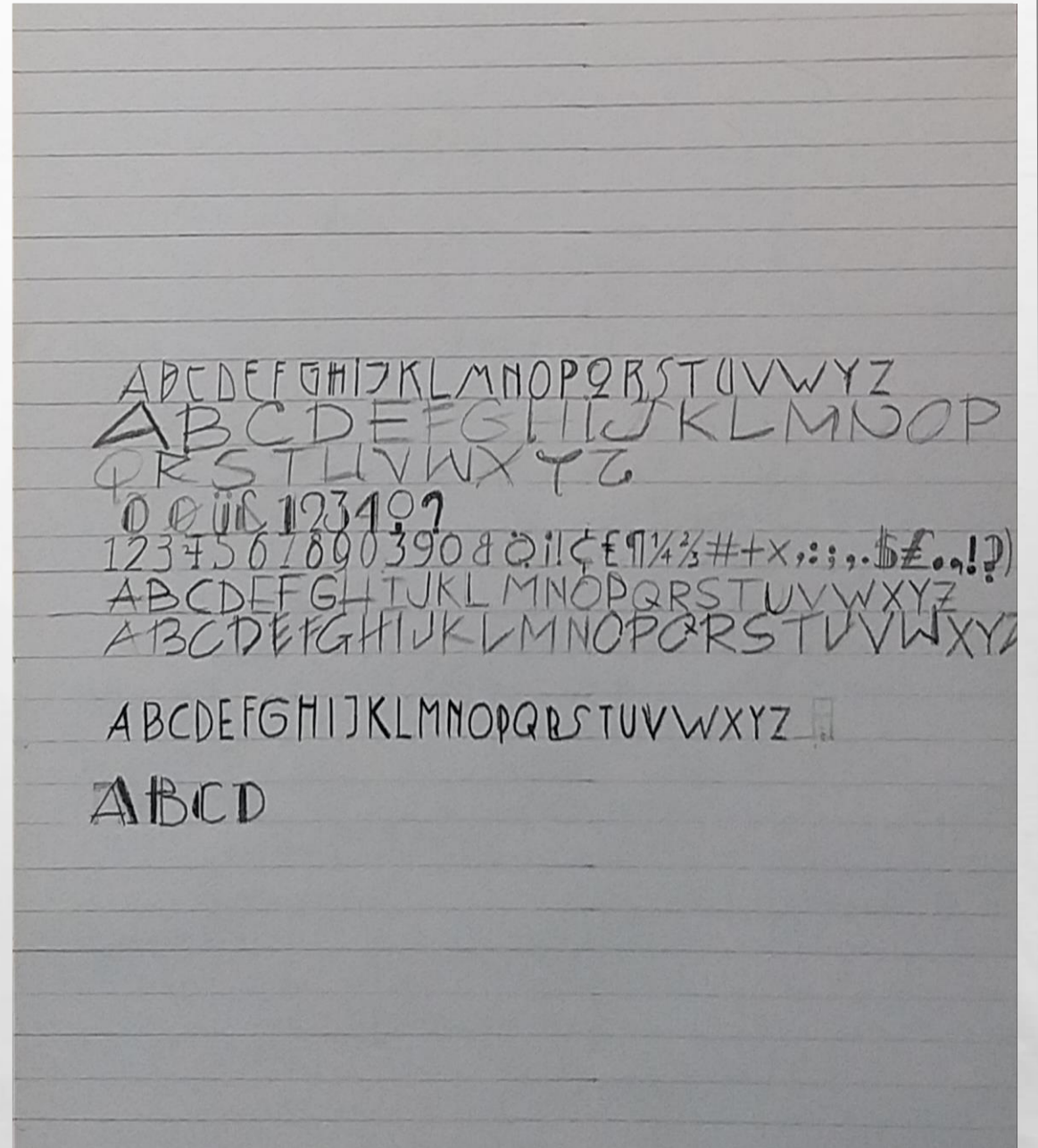

FONTURI PENTRU ARHITECTURĂ



POLIEDRE REGULATE

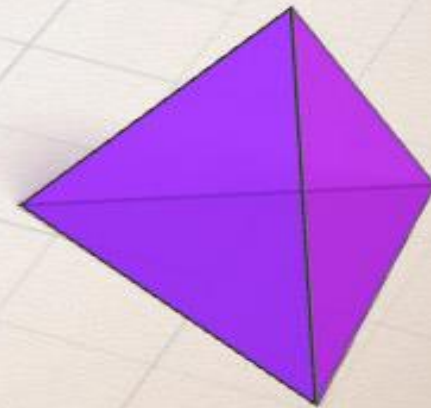
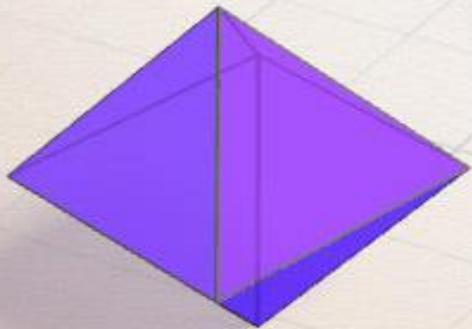

REPREZENTAREA CUBULUI ROTIT AȘEZAT PE UN VÂRF/ TETRAEDRUL ÎNSCRIS ÎNTR-UN CUB

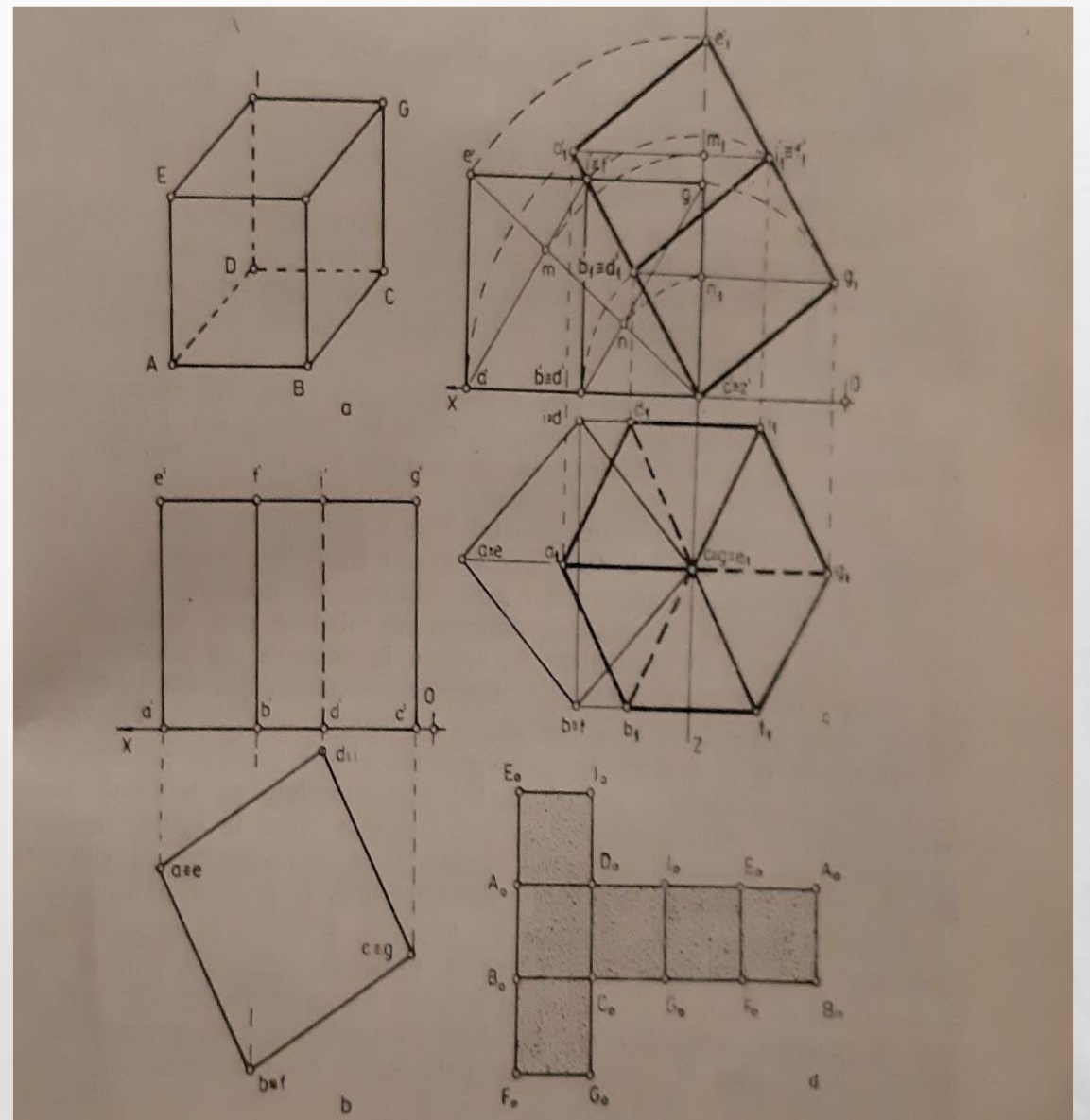
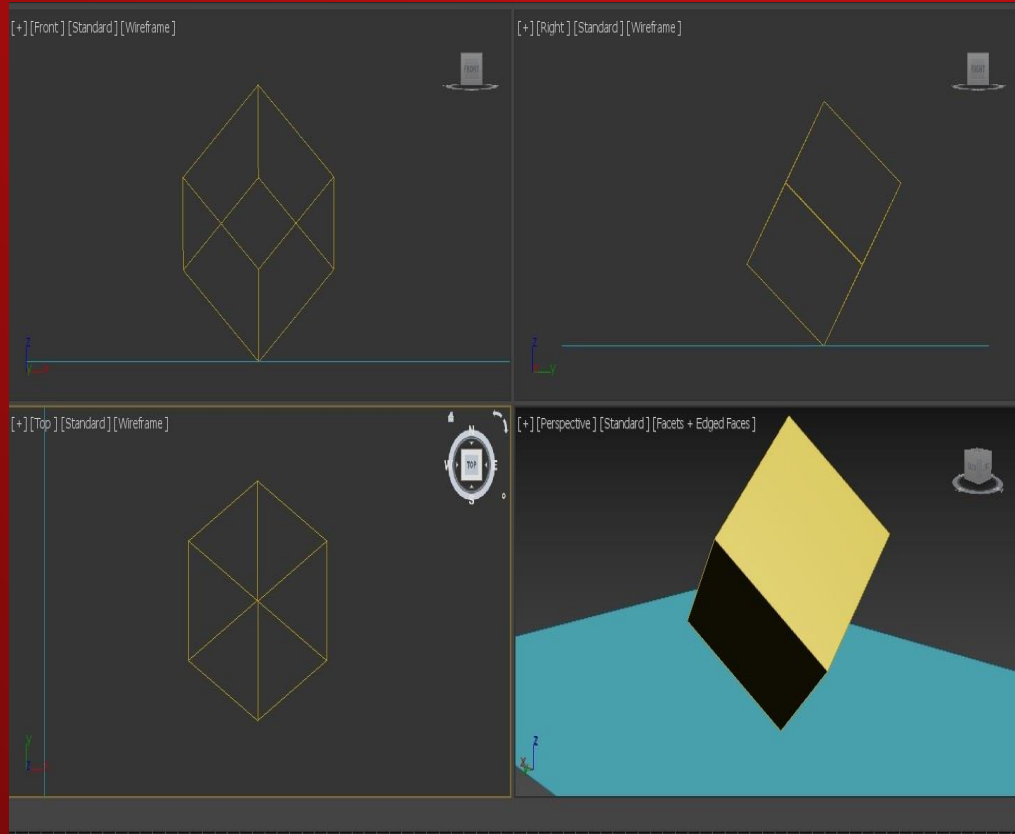

CERCUL ÎN AXONOMETRIE. CONUL AȘEZAT PE FAȚA UNUI CUB

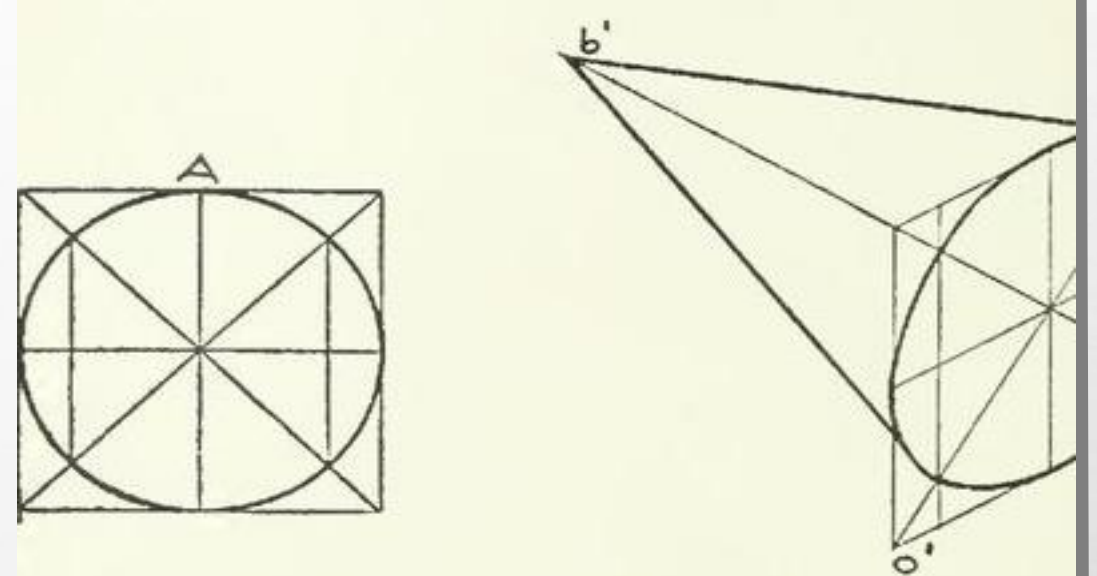
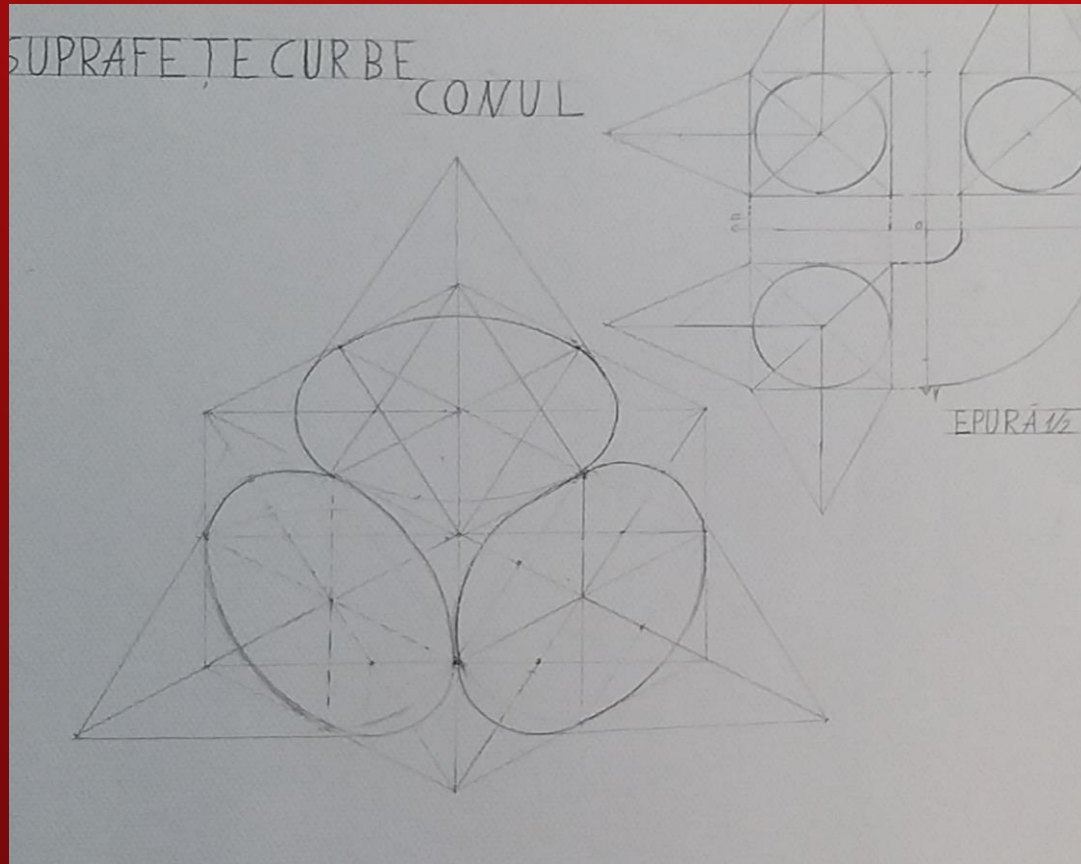
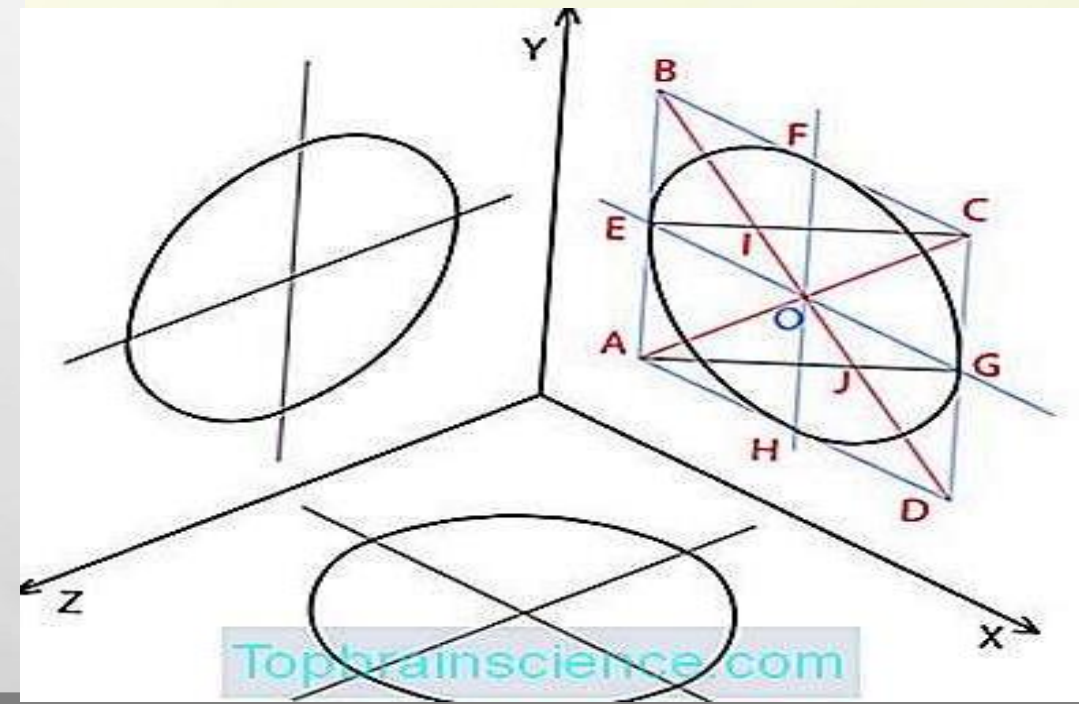
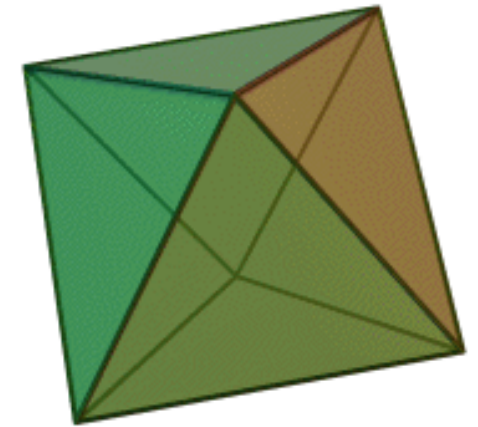
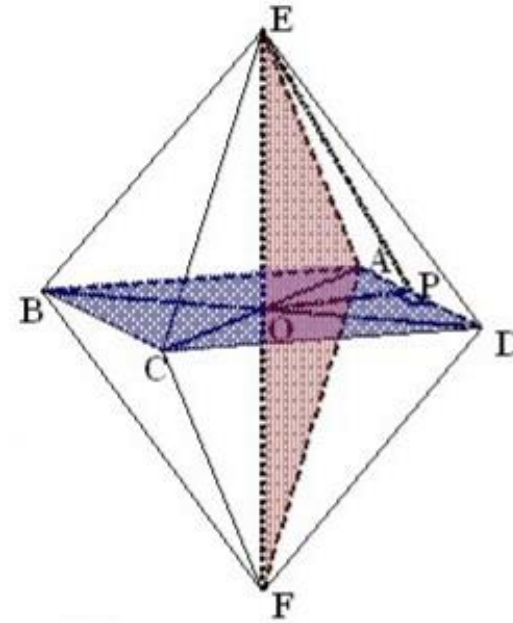
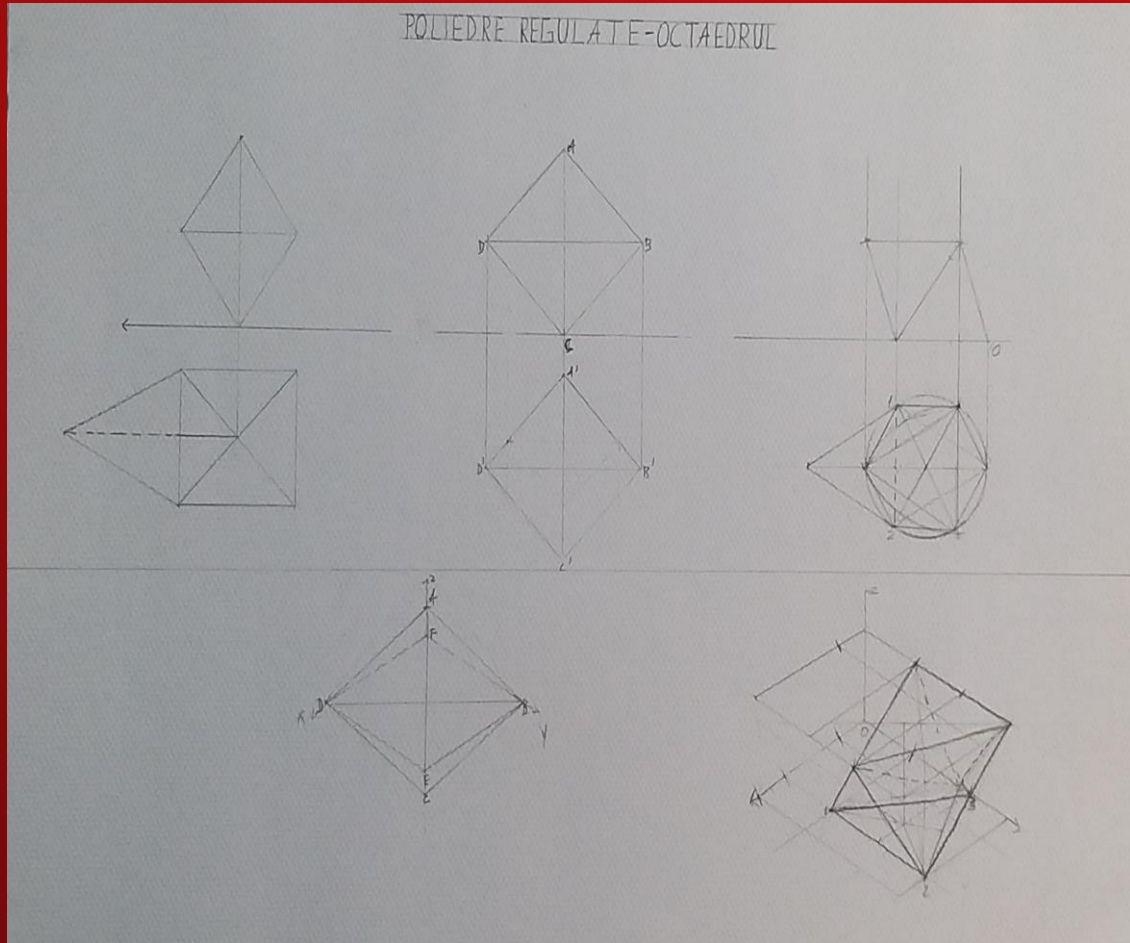

Fig. 90. Drawing a Cone in Isometric.



OCTAEDRUL AȘEZAT PE O FATĂ /OCTAEDRUL AȘEZAT PE UN VÂRF



CONSTRUIREA UNUI CILINDRU AȘEZAT PE O PRISMĂ

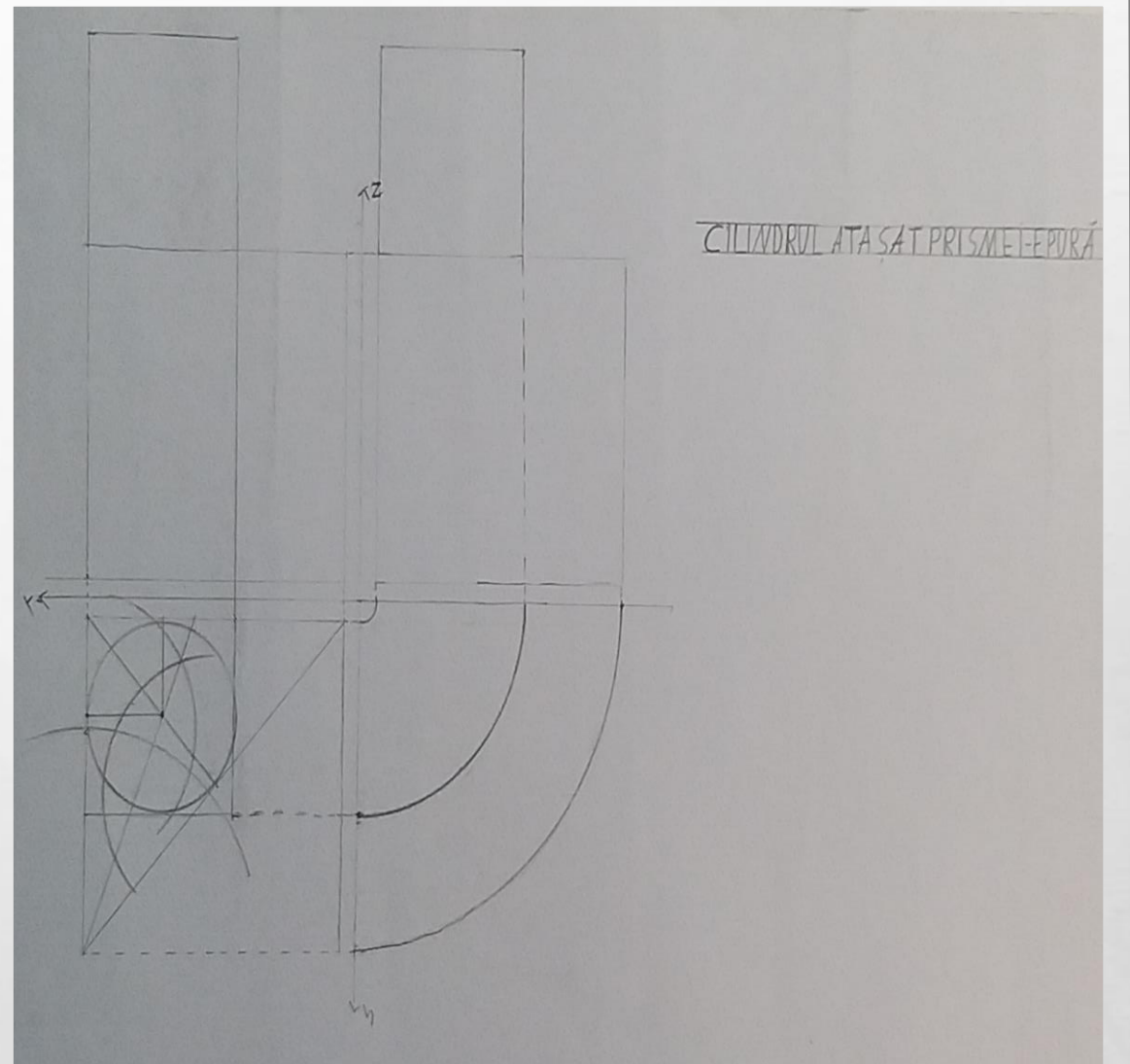
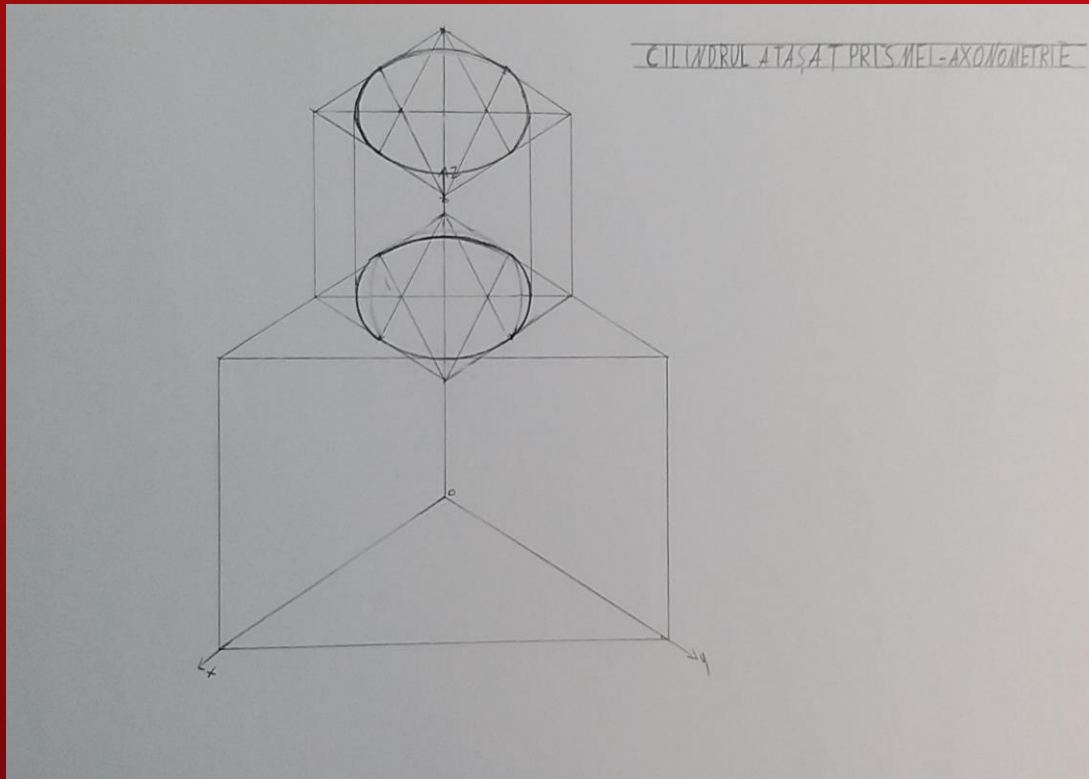

PIRAMIDA HEXAGONALĂ AȘEZATĂ PE O FAȚĂ

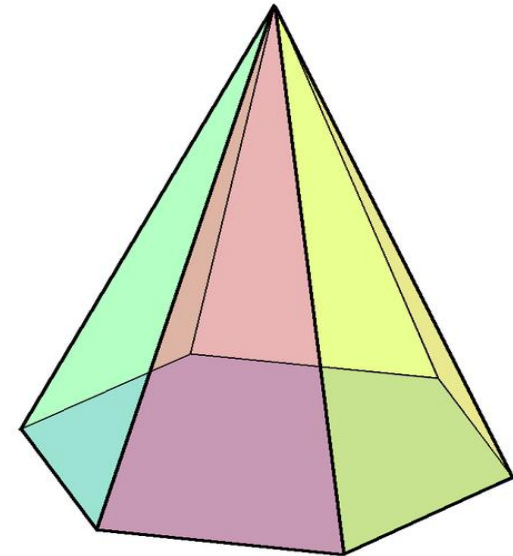
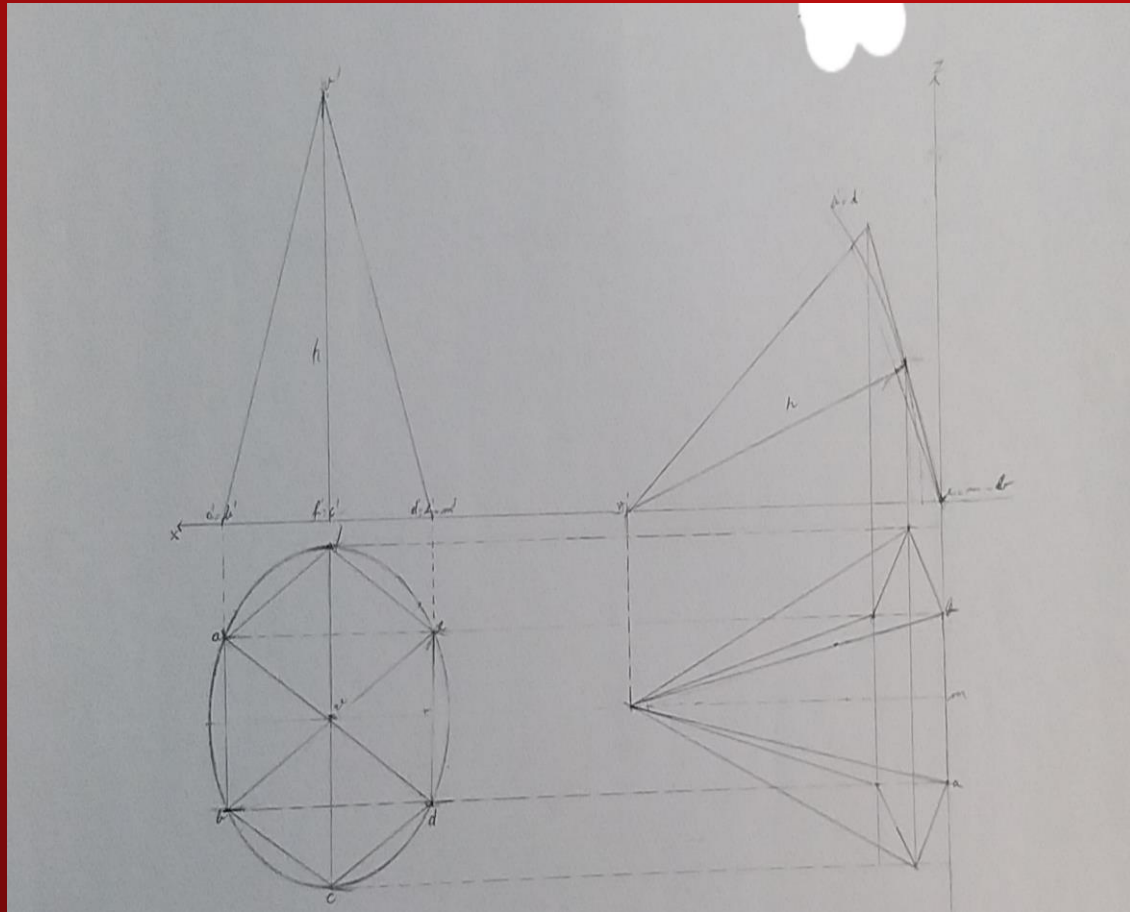

$h = 6$

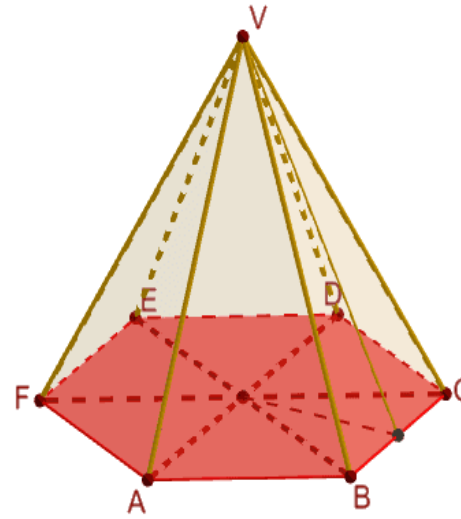
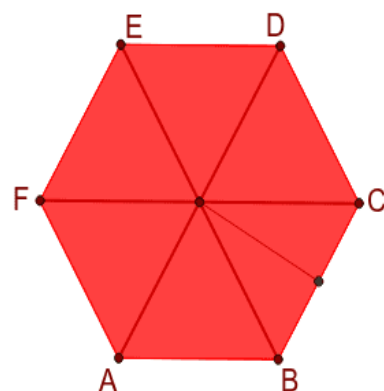

CONSTRUCTIE PENTAGON REGULAT DE LATURA DATA

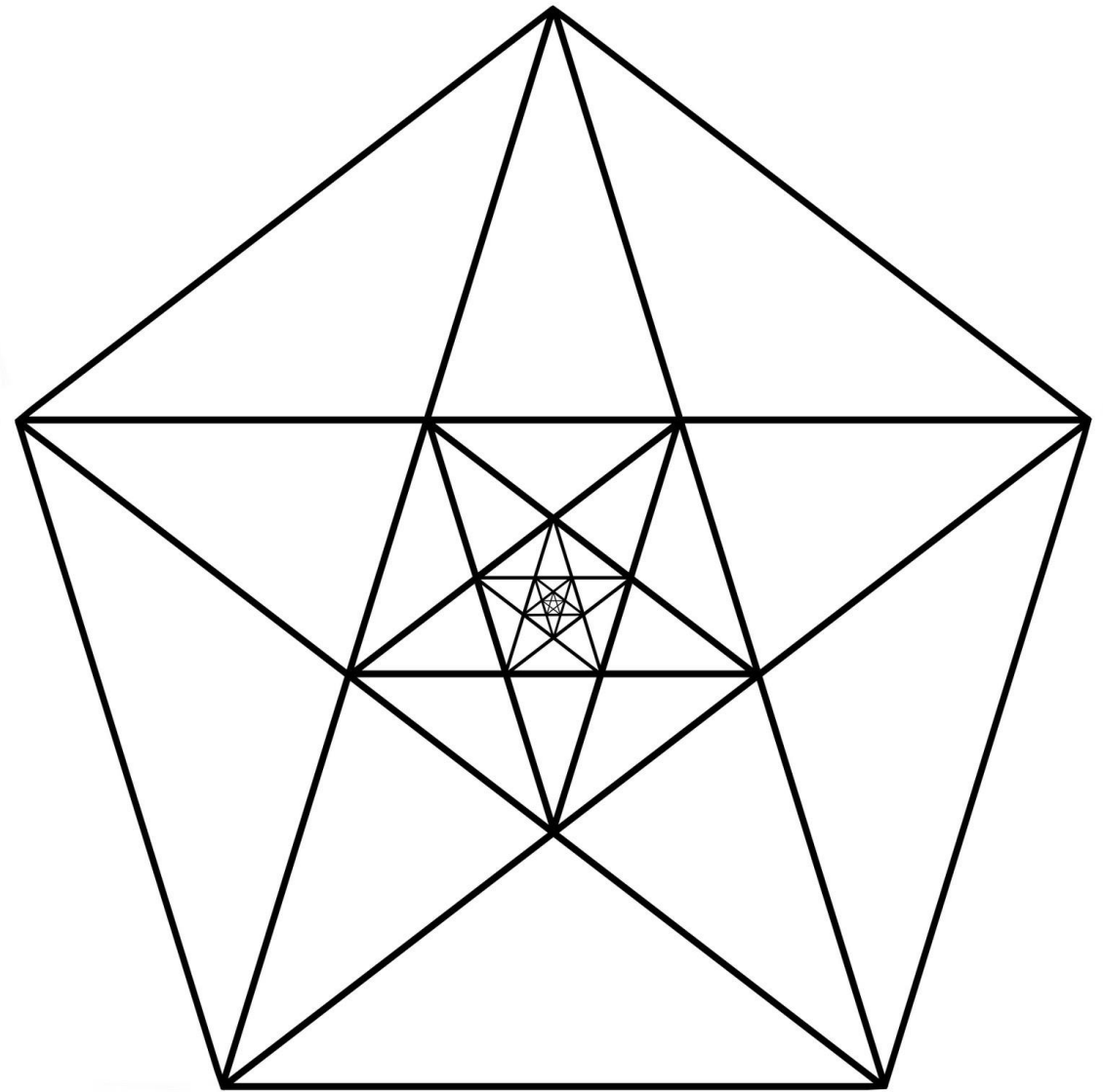
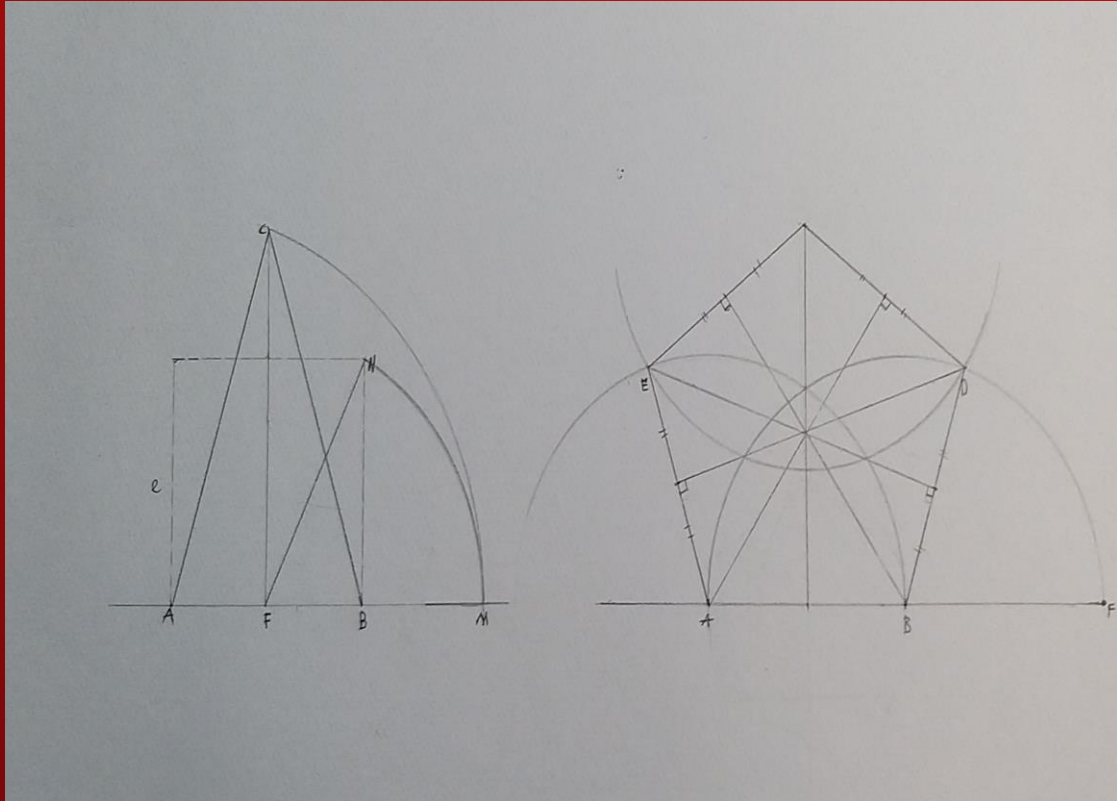

ICOSAEDRUL ASEZAT PE UN VARF

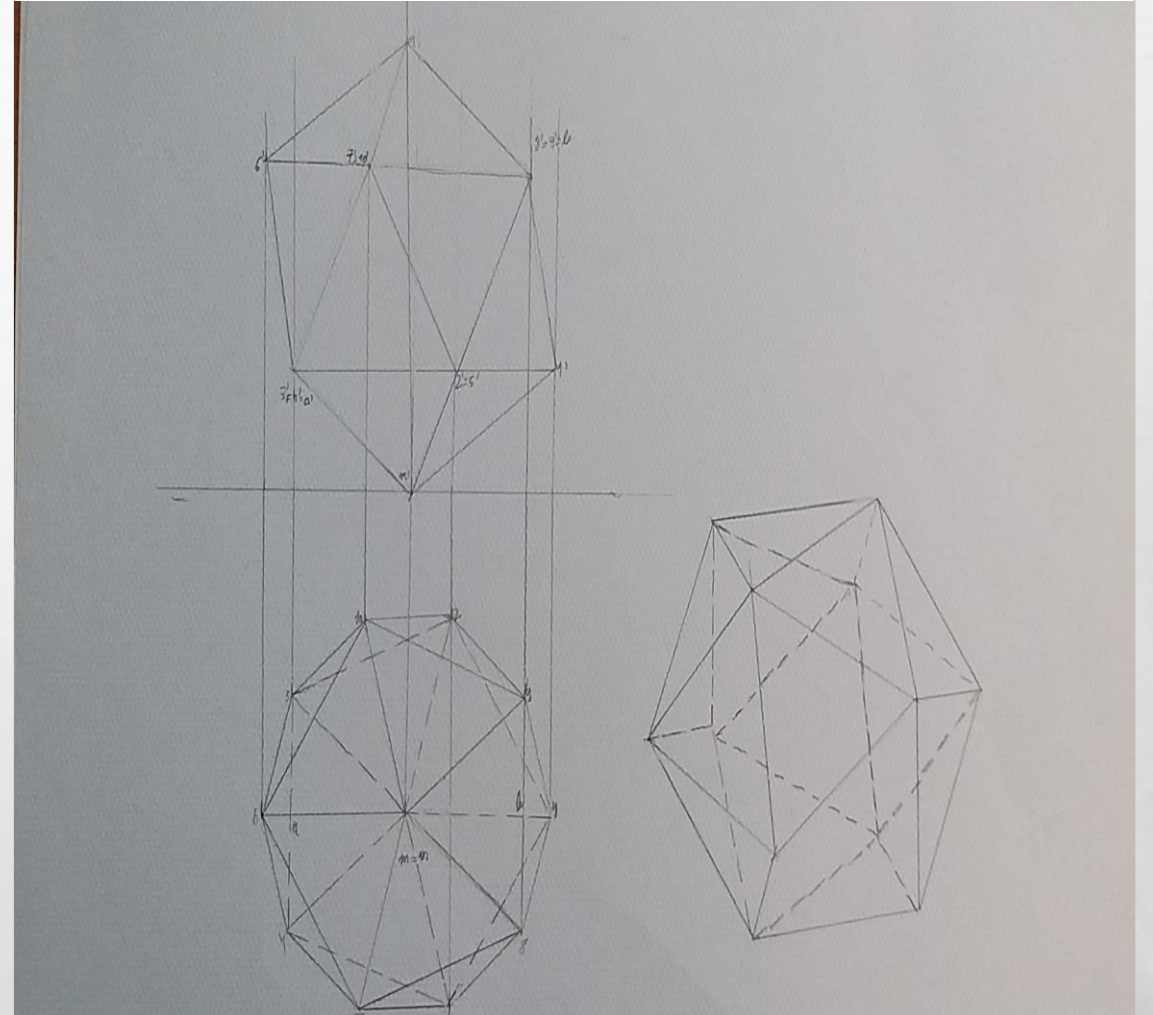
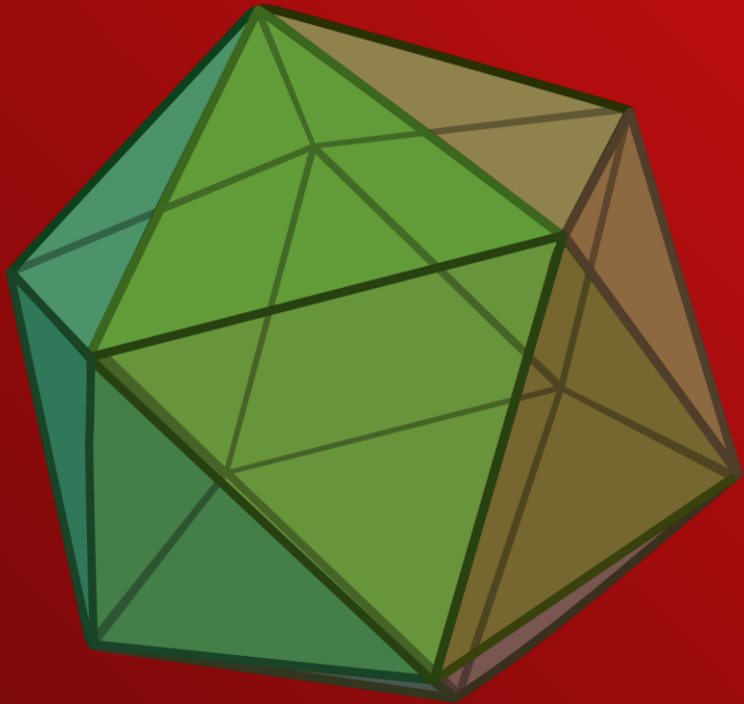

DODECAEDRU ASEZAT PE O FAȚĂ

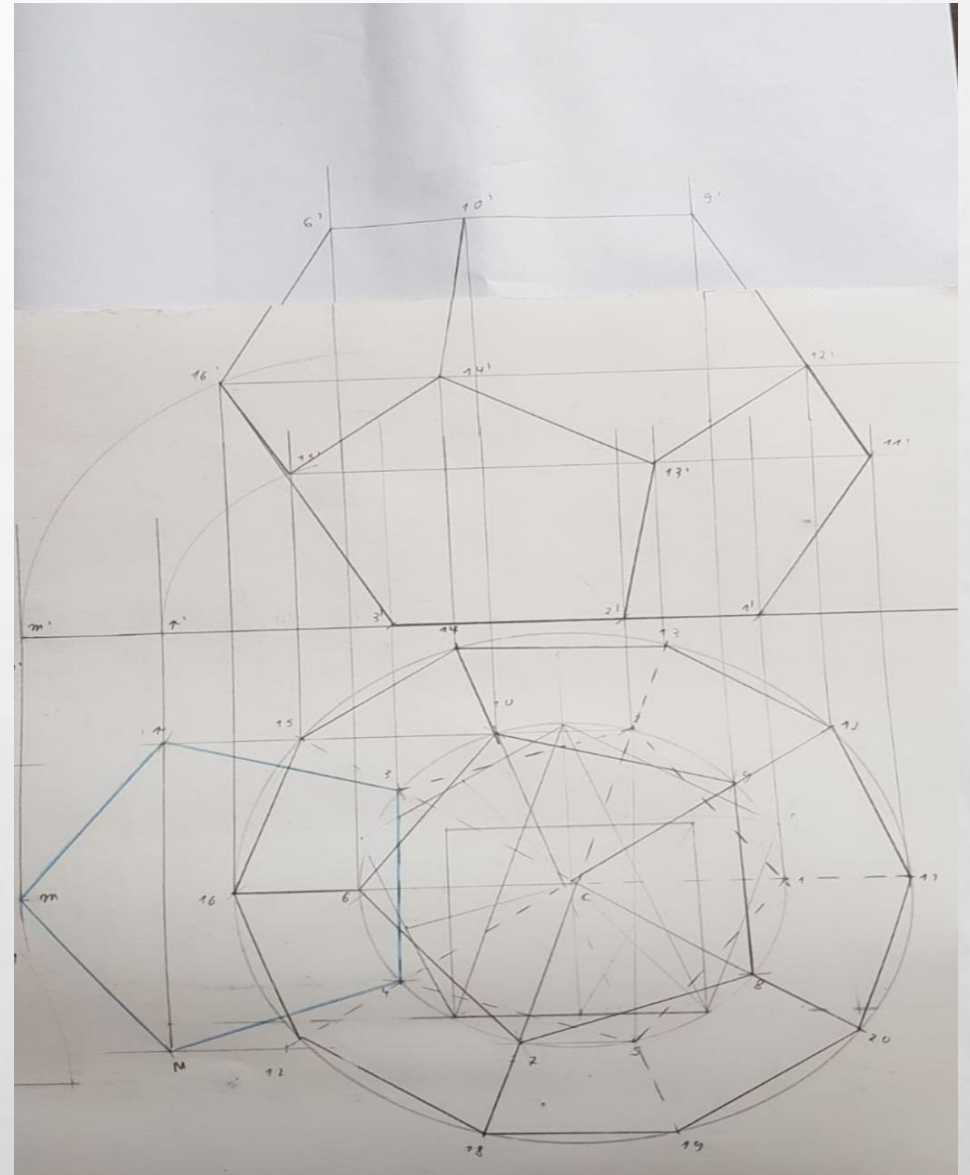
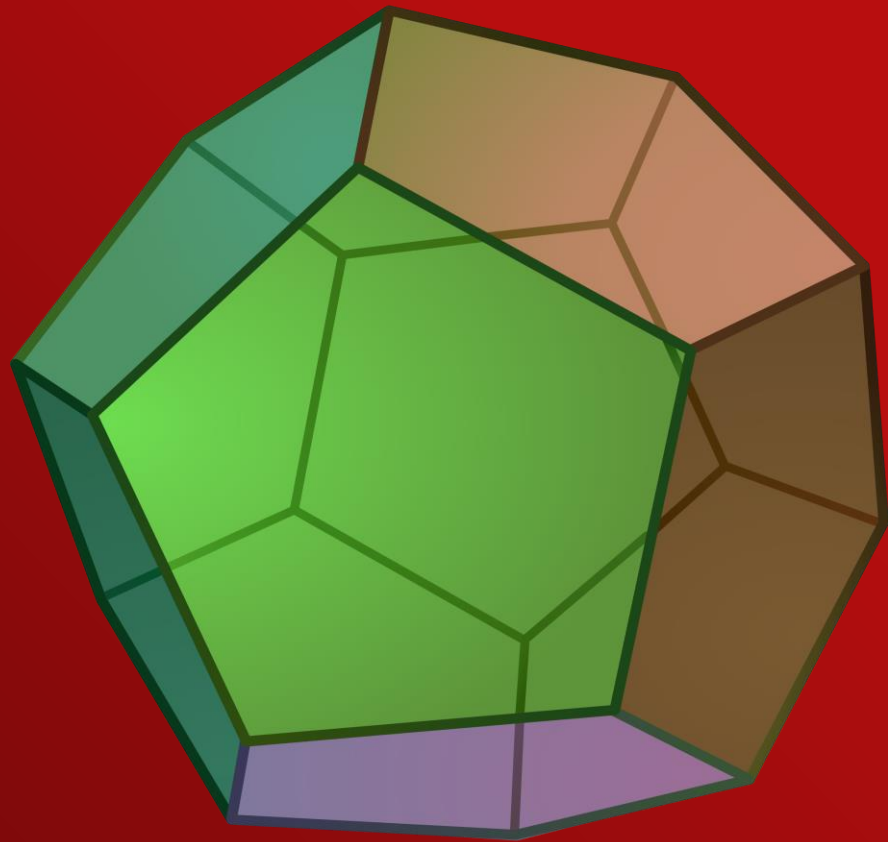

CILINDRUL ATASAT UNUI OCTAEDRU

